

SERVICE BULLETIN 0807-001
3-30-2009, Revision A

MULTI-GROOVE SUPERCHARGER BELT

Background:

V type drive belts for engine accessories have largely been replaced with multi-v or multi-groove belts. New aircraft have multi-groove belts where possible. Multi-groove belts are stronger, produce less heat, and are lighter. The Service Bulletin outlines the procedure for installing a multi-groove belt for the supercharger drive in selected Cessna 182 aircraft modified with Forced Aeromotive Technologies superchargers.

Eligibility:

Cessna 182 aircraft models G through Q, serial numbers 18255101 through 12855125 and 18255845 through 18266590 modified with Forced Aeromotive Technologies supercharger systems, STC # SA10232SC and SE10233SC.

Compliance: Voluntary

Materials:	<u>Part</u>	<u>Quantity</u>
	182LR440-M or 182U450-M belt	1
	182LR014-2 or 182U014-2 engine pulley	1
	182LR009-2 supercharger pulley	1
	FAT Inc. drawing P/N 182LR0116, 182LR0117, or 182LR0118.	1

Alteration:

For existing supercharger installations:

1. Disconnect the battery.
2. Remove the upper and lower cowling.
3. Loosen the engine mount bolts at the firewall and using a hoist, slide the engine forward about 2 inches.
4. Loosen the supercharger idler and remove the supercharger belt and loosen the alternator and remove the alternator belt. Remove the alternator and remove the 4 nuts and washers securing the alternator support to the engine remove and modify the support per FAT Inc. drawing P/N 182LR0116, or P/N 182LR0017, or P/N 182LR0018 as appropriate. (figure 1)
5. Reinstall the modified alternator support and alternator.
6. Remove the alternator/supercharger drive pulley from the rear of the engine and replace it with the new double pulley, P/N182LR014-2, using the existing hardware. Tighten to 37.5 to 41.2 ft. lbs. (Figure 1)

Forced

7161 S. Peoria 18E, Englewood, Co 80112

Aeromotive

(720) 348-0622 FAX (303) 799-6443

Technologies

forcedaeromotive.com

7. Reinstall the alternator belt, FAT P/N 182355, and tighten the belt by rotating the alternator. (Figure 1)
8. Remove the supercharger pulley (figure 2) and replace it with pulley P/N 182LR009-2 using the existing hardware.
9. Install the supercharger belt, FAT P/N182LR440-M or 182U450-M, and tighten the belt by pushing down on the idler pulley, tensioning the belt . Tighten the belt until a 9.5 lb. pull at the center of the lower portion of the belt results in a .25 inch of belt deflection. Recheck belt tension in the first 2-10 hours and adjust to a setting of 7.0-8.0 pounds.
10. Reinstall the engine and confirm clearance of all cables, hoses, wires, etc.
11. Reconnect the battery.
12. Check engine operation with a ground run.
13. Reinstall the cowling.

Remove drive pulley and replace with P/N 182LR014-2

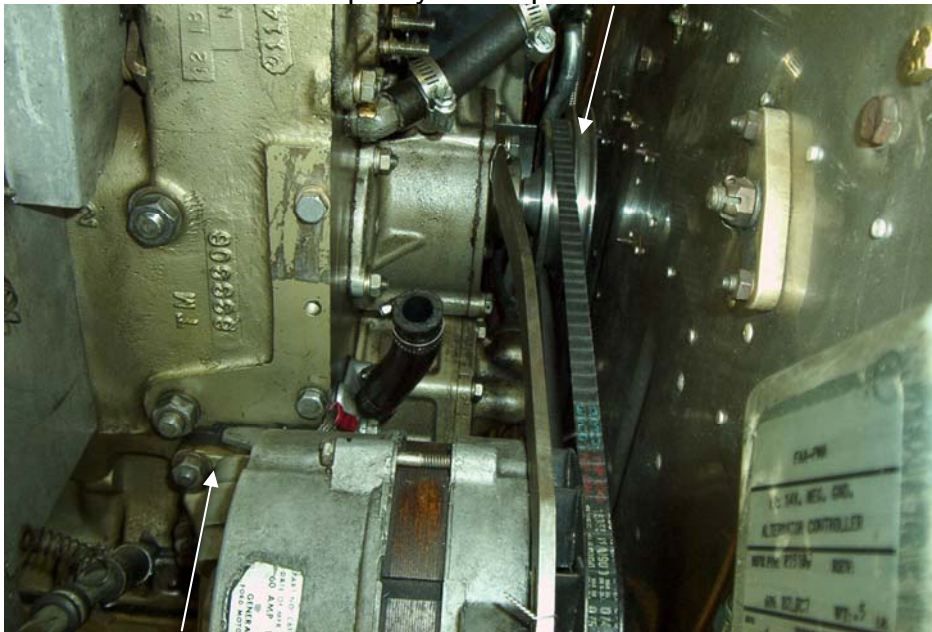

Figure 1

Alternator support

Forced

7161 S. Peoria 18E, Englewood, Co 80112

Aeromotive

(720) 348-0622 FAX (303) 799-6443

Technologies

forcedaeromotive.com

Supercharger idler

Remove supercharger pulley, replace with P/N 182LR009-2

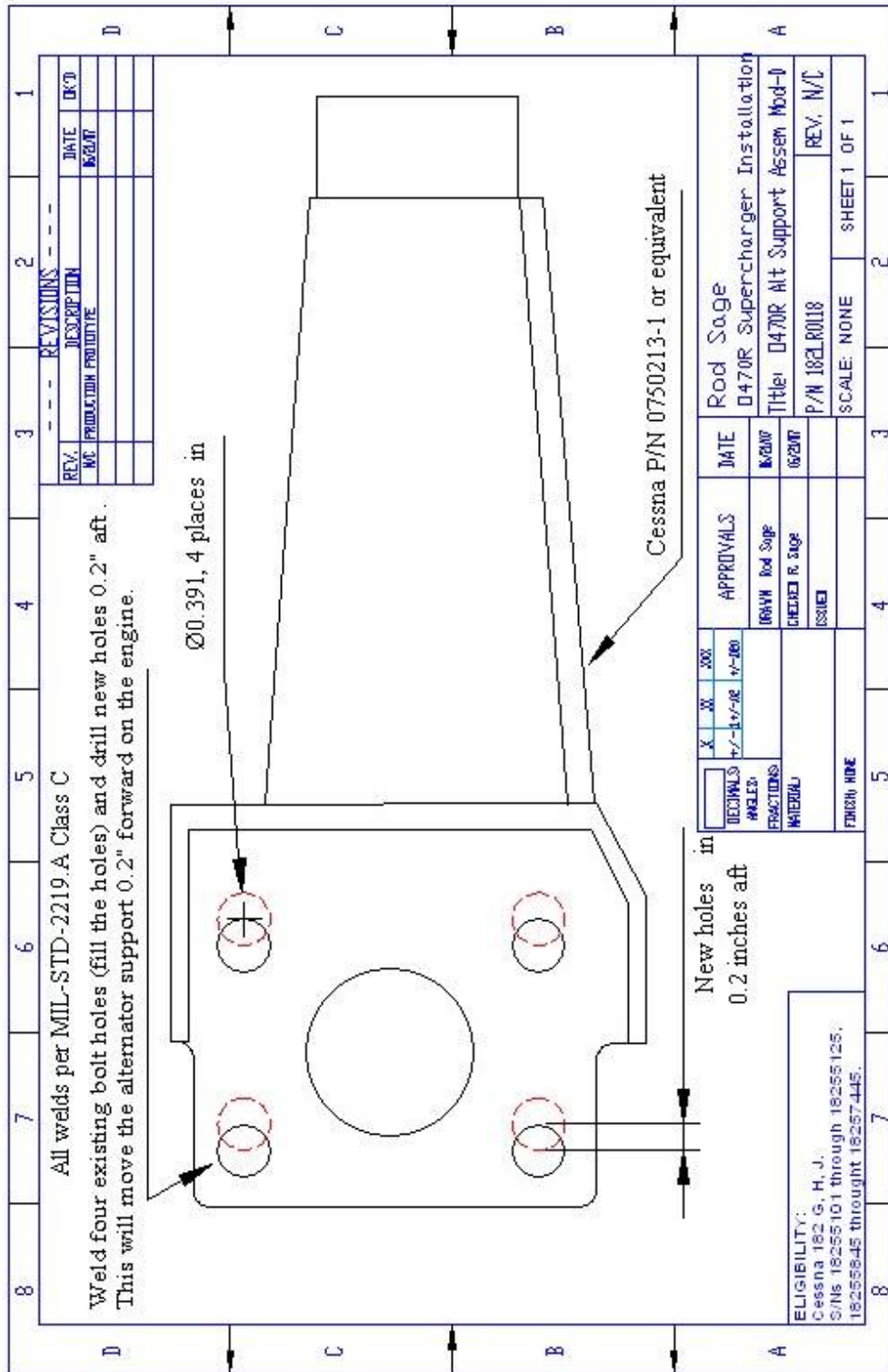

Figure 2

For new installations:

Installation is per FAT Inc. Installation Instructions, document II-182, revision F, dated January 4, 2005 or later approved revision with the following changes:

1. After step 6 remove the alternator and remove the 4 nuts and washers securing the alternator support to the engine (figure 1), remove and modify the support per FAT Inc. drawing P/N 182LR0116, or P/N 182LR0017, or P/N 182LR0018 as appropriate. Reinstall the modified alternator support and alternator.
2. Step 7, replace the removed alternator pulley with P/N 182LR014-2, instead of P/N 182LR014, or P/N182U014-2 instead of P/N 182U014.
3. Step 30, install Supercharger Assembly #2 instead of Supercharger Assembly #1.
4. Step 31, install supercharger belt P/N 182LR440-M instead of P/N 182435 or P/N 182U450-M instead of P/N 182445. Tighten the belt by pushing down on the idler pulley, tensioning the belt . Tighten the belt until a 9.5 lb. pull at the center of the lower portion of the belt results in a .25 inch of belt deflection. Recheck belt tension in the first 2-10 hours and adjust to a setting of 7.0-8.0 pounds.



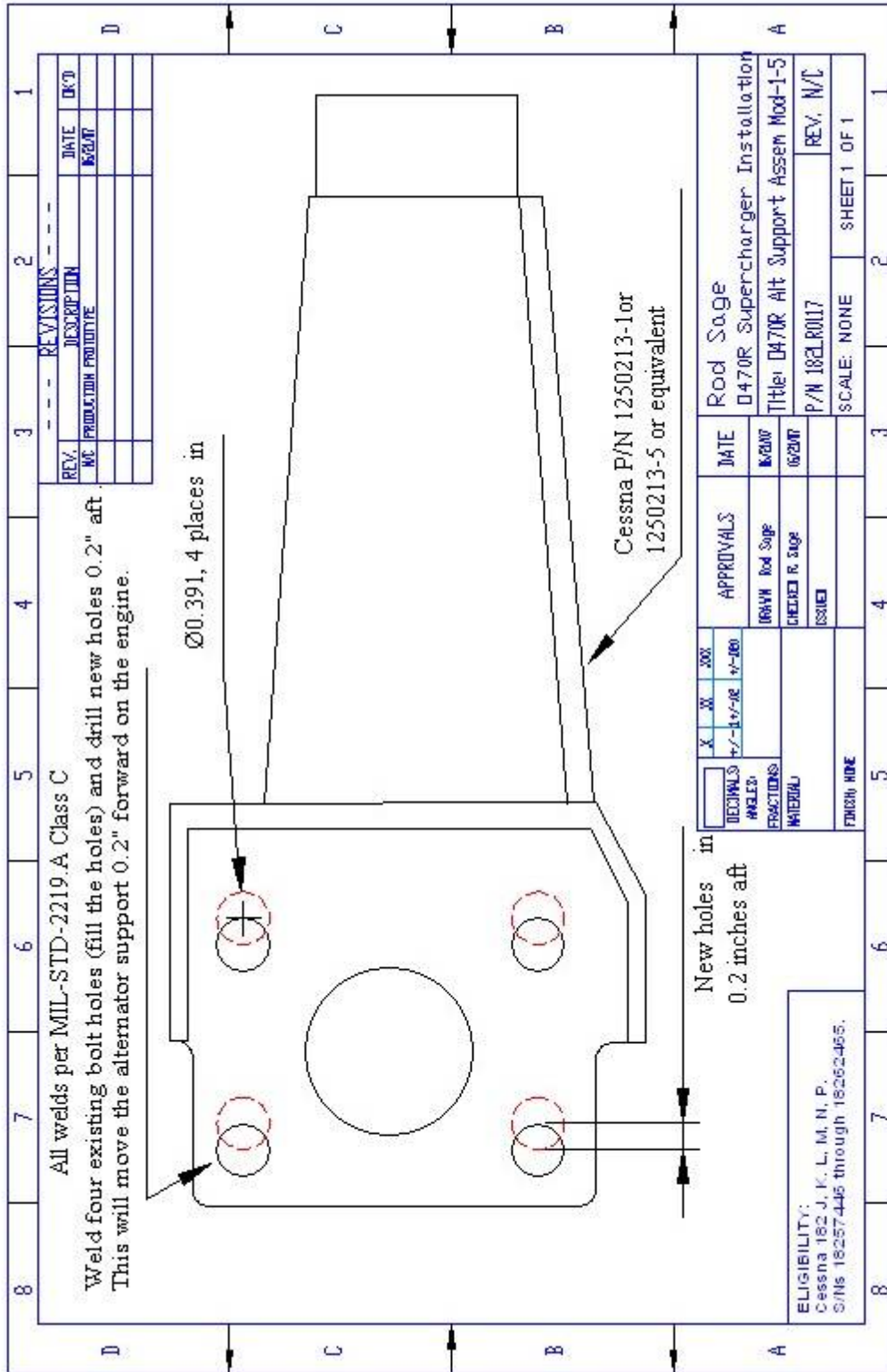

REV	DESCRIPTION	DATE	BY
1	PRODUCTION PROTOTYPE		

APPROVALS	DATE	ROD SAGE
DRAWN	10/20/07	ROD SAGE
CHECKED	10/20/07	ROD SAGE
ISSUED		
TITLE: D470R Alt Support Assem Mod-1-5		REV: N/C
P/N 182L0017		SCALE: NONE
SHEET 1 OF 1		

ELIGIBILITY:
Cessna 182 J, K, L, M, N, P,
S/Ns 18257445 through 18262465.

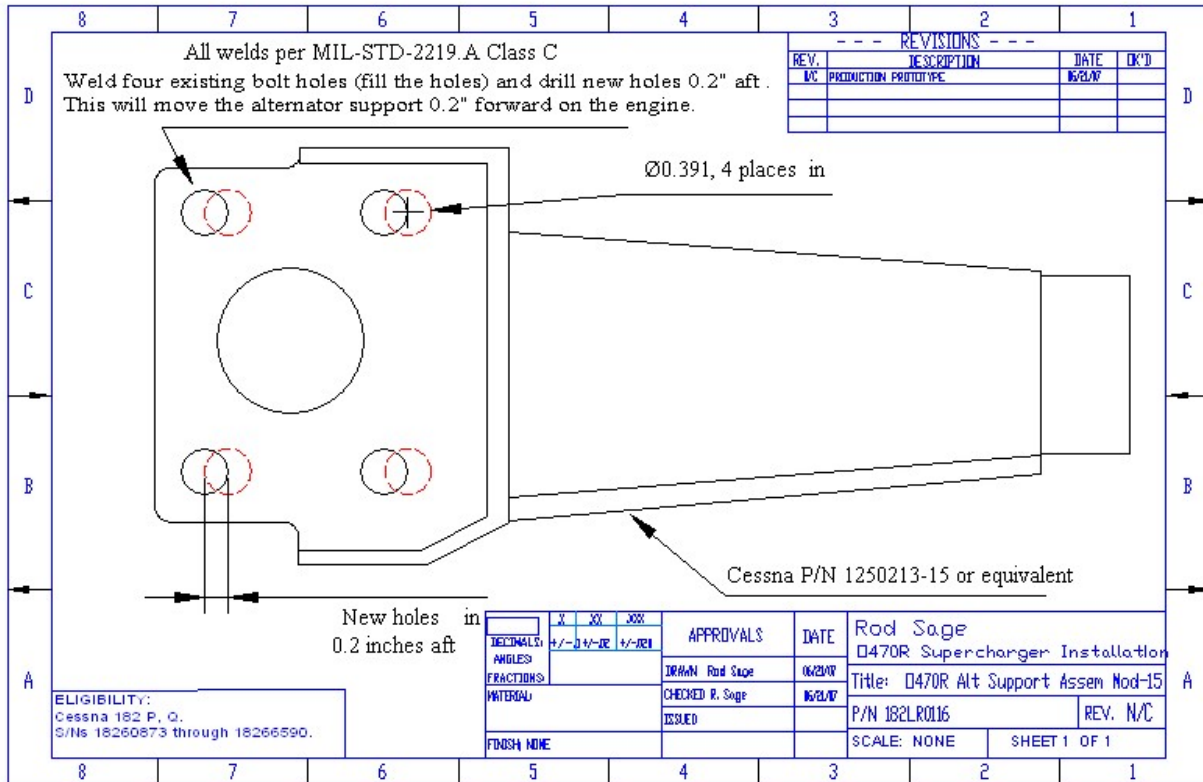

Contact FAT for technical assistance.

END